



PREDICTING BITCOIN PRICE WITH THE LSTM MODEL

Osman Gazi Polat

Istanbul Ticaret University, Turkey

Ayben KOY

Istanbul Ticaret University, Turkey

Received: January 23, 2024

Accepted: March 14, 2024

Published: June 01, 2024

Abstract:

Forecasting techniques and models play a pivotal role in guiding individuals and organizations towards informed decision-making and prudent investments. The accuracy of the forecast enables successful decisions and allows investors to maximize utility. The developments in finance and finance-related technologies around the world, along with innovative financial instruments, have piqued the interest of investors. Undoubtedly, the most prominent among these advancements is Bitcoin, a product of blockchain technology. In this study, future predictions will be generated using the LSTM model, relying on the historical data of Bitcoin and crucial market predictors. Specifically, three distinct datasets will be employed, each drawing one indicator from four different indicator types. With these datasets in hand, the study aims to predict the next ten data points pertaining to Bitcoin's performance, employing the relevant methodology. This forecast serves as a guiding model for investors and as a risk reduction study, given that it encompasses 3 different management scenarios for Bitcoin.

Keywords:

LSTM, Bitcoin, Cryptocurrency, Neural Network, Prediction

JEL Code:

G12, G14, C53

1. Introduction

In the contemporary landscape, cryptocurrencies, with Bitcoin at the forefront, have engendered substantial intrigue within the financial domain. The inception of Bitcoin in 2009 marked the genesis of a decentralized currency paradigm, amassing a substantial global user base. This ascent in popularity has galvanized investor attention, thereby instigating a significant surge in trading activity across cryptocurrency markets. The bedrock of this decentralized ethos lies in the efficacy of blockchain technology, which facilitates expeditious and cost-effective transactions, circumventing the traditional intermediary role of financial institutions. Nonetheless, the trajectory of Bitcoin prices is notably characterized by pronounced volatility, prompting investors to proactively discern price fluctuations to harness potentially lucrative investment prospects (Alpago, 2018). However, Bitcoin's idiosyncratic attributes markedly diverge from established financial market norms, thus warranting circumspection when applying conventional forecasting methodologies for Bitcoin price projection. Given the inherent uncertainties, the capacity to anticipate price movements within cryptocurrency markets assumes paramount significance.

Foretelling the price trajectory of Bitcoin is inherently contingent upon the interplay of market demand and supply dynamics. The finite supply of Bitcoin, constricted to 21 million units, serves as a pivotal fulcrum within the realm of supply-demand equilibrium. Additionally, the multifaceted determinants impinging upon Bitcoin prices encompass regulatory frameworks, pivotal news events, technological advancements, and the valuation trajectories of concomitant cryptocurrencies. Therefore, forecasting Bitcoin prices becomes an intricate process, given the complexity of these factors.

Price prediction in cryptocurrency markets stands as a pivotal determinant influencing investor decisions. Accurate price forecasts can empower investors to respond adeptly to market fluctuations and seize lucrative investment opportunities. Consequently, technologies and methodologies for price prediction in cryptocurrency markets assume

a substantial role as indispensable tools for investors. Within this context, leveraging contemporary financial theories such as algorithmic trading and the efficient markets hypothesis, predictions concerning Bitcoin prices can be formulated. Algorithmic trading entails the execution of financial asset transactions through the utilization of mathematical algorithms. Conversely, the efficient markets hypothesis posits that in an environment where all participants share equivalent information, financial markets determine prices rationally. Consequently, forecasting models ought to be rooted in the principles of efficient markets.

Against this backdrop, this article endeavors to provide a framework for forecasting Bitcoin prices through the utilization of modern financial theories, notably algorithmic trading and the efficient markets hypothesis. Simultaneously, this endeavor contributes to the extant literature by facilitating insights into innovative financial assets, including Bitcoin and other cryptocurrencies.

2. Literature

In recent years, the advancements in the realm of artificial intelligence methodologies have led to a notable proliferation in the volume of research endeavors dedicated to the domain of price prediction. This surge in scholarly pursuits can be attributed to the potent synergy between the escalating complexity of financial markets and the increasingly sophisticated capabilities of artificial intelligence (AI) techniques. As financial markets continue to exhibit intricate interplays of multifarious determinants, ranging from macroeconomic indicators to subtle sentiment shifts, the application of AI-driven methodologies has emerged as a promising avenue for enhancing the accuracy and efficacy of price prediction models.

In a study conducted by Sel, Zengin, and Yıldız (Sel vd.,2020) in the year 2020, an investigation into the prediction of the relationship between alternative investment instruments and Bitcoin prices was undertaken through the utilization of artificial neural networks. The study employed one of the most frequently utilized models, the error backpropagation model, which facilitates the adaptation of neuron count within the range of 1 to 20 during prediction processes. In the course of forecasting Bitcoin's price for January 2019, artificial neural networks were employed, and data points were selected based on common trading days coinciding with open exchanges, given the variance in data across different countries. It has been posited in this study that the elevated predictive efficacy of the artificial neural network model can be attributed to the discernible influence of U.S. indices.

Similarly, Wardak and Rasheed (Wardak and Rasheed, 2022) endeavored to predict Bitcoin prices by employing the Long Short-Term Memory (LSTM) recurrent neural network model. This study, conducted over a span of five years, yielded an accuracy rate of 95.7%. Livieris, Kiriakidou, Stavroyiannis, and Pintelas (Livieris vd., 2021) conducted a comprehensive empirical investigation utilizing data pertaining to the first three cryptocurrency units, namely Bitcoin (BTC), Ethereum (ETH), and Ripple (XRP). Through intricate experimental analysis, the proposed model's efficacy in processing complex cryptocurrency data efficiently, mitigating overfitting, and reducing computational costs as compared to traditional fully connected deep neural networks has been demonstrated.

Upon examining the extant research, it becomes evident that the Long Short-Term Memory (LSTM) method has been prominently employed for Bitcoin price forecasting. Nonetheless, it is discernible that diverse parameters beyond price have recurrently featured within these research endeavors. Within this context, the study titled "Bitcoin Price Prediction Based on Artificial Neural Networks and Blockchain Data," conducted by Yavuz, Üstün, Zen, Taş, and Çağlar (Yavuz vd.,2020), employs artificial neural network techniques utilizing blockchain and Bitcoin parameters spanning the years 2009 to 2018. The study establishes a remarkably high statistical significance associated with wallet usage rate, difficulty, daily wallet transaction count, average block size, transaction confirmation time, mining yield, HASH value, cost per job, transaction volume in dollar equivalent, total transaction count, daily transaction count, total circulating Bitcoin amount, network gap, and Ethereum values.

Chen, Z., Li, C., and Sun, W. (Chen vd.,2020) highlight that the average accuracy of statistical methods is 65.0%, surpassing the average accuracy of machine learning models at 55.3%. Among these, the Long Short-Term Memory achieves the most favorable outcomes with an accuracy of 67.2%. In a similar vein, the study "Bitcoin Price Prediction with Neural Networks" conducted by Struga and Qirici (Struga and Qirici, 2018) utilizes the Long Short-Term Memory variant of Recurrent Neural Networks for Bitcoin price prediction. This study incorporates data derived from stock indices, sentiment analysis, blockchain, and Coinmarketcap for forecasting Bitcoin prices. Notably, both studies underscore that qualitative data in isolation yields inconclusive results.

In addition to studies employing the LSTM model with varying parameters, the literature also encompasses research comparing LSTM with different modeling approaches and evaluating their performance. In one such study, conducted by Andi (Andi, 2021), both an LSTM model and a logistic regression learning model were employed for Bitcoin price prediction. Using volume, closing, opening, and high values, daily Bitcoin prices from 2014 to 2021 were considered, utilizing a total of 31,942 data points with June 2017 data set aside for testing purposes. The study revealed accuracy values of 89.1% for the Linear regression model, 91.4% for the Lasso Algorithm model, and 97.2% for the proposed logistic regression with LSTM model. Notably, the proposed logistic regression with LSTM model yielded the most accurate outcomes.

Kwon et al. (Kwon, 2019) substantiate in their study that the LSTM model exhibits relatively superior prediction performance compared to the cryptocurrency gradient boosting model, presenting an approximate 7% performance enhancement over the GB model. Hamayel and Owda (Hamayel and Owda, 2021) demonstrate in their investigation that GRU outperforms other algorithms with MAPE values of 0.2454%, 0.8267%, and 0.2116% for BTC, ETH, and LTC, respectively. The RMSE values for the GRU model were found to be 174.129 for BTC, 26.59 for ETH, and 0.825 for LTC. Based on these outcomes, the GRU model emerges as an efficient and reliable alternative for the targeted cryptocurrencies, surpassing LSTM and bi-LSTM.

Conversely, Huang et al. (Huang, 2021) have proven that autoregression models outperform long short-term memory (LSTM) by 18.5% and 15.4%, respectively. For predicting future time frame price trends, they propose a LSTM-based recurrent neural network that utilizes past cryptocurrency price movements. In contrast, Latif et al. (Latif et al., 2023) found that unlike ARIMA, which merely tracks Bitcoin price trends, the LSTM model can predict both direction and value within a specific time frame. Despite the complexity of ARIMA, LSTM is capable of forecasting fluctuating Bitcoin prices.

Similarly, in the study "Cryptocurrency Bitcoin: Price Prediction with ARIMA and Artificial Neural Networks" conducted by Şahin (Şahin, 2018), daily price data for Bitcoin from February 2, 2012, to January 9, 2018, was employed. The research employed both the autoregressive integrated moving average (ARIMA) and artificial neural networks (ANN) as linear and non-linear methods, respectively, for Bitcoin price prediction. The ANN model, specifically the multilayer perceptron (MLP), yielded successful outcomes in terms of both price direction and predicted prices from January 10, 2018, to January 18, 2018, compared to the ARIMA model. However, it can be asserted that the ARIMA model also yielded accurate prediction results from January 15, 2018, to January 18, 2018. The analysis demonstrated that the ANN model's predicted prices closely aligned with realized prices in both price direction and magnitude.

Kwon, et al (Kwon et al., 2019) examined the predictability of Bitcoin prices using LSTM and ARIMA techniques through the analysis of Bitcoin tweets. The LSTM model's root mean square error (RMSE) was reported as 198.448 (single feature) and 197.515 (multiple features), while the ARIMA model's RMSE was 209.263, underscoring the greater accuracy of the multi-feature LSTM model.

In light of the reviewed studies and conducted research, it has been observed that the LSTM model proves to be effective in Bitcoin price prediction. When compared with linear models, it becomes evident that LSTM modeling yields a notably high accuracy rate. These findings collectively underscore the robustness of the LSTM model in predicting Bitcoin prices, solidifying its prominence within the landscape of predictive modeling techniques for cryptocurrency markets.

3. Data

In many studies in the literature, LSTM models have been employed for Bitcoin price prediction. However, the majority of these studies have utilized Bitcoin closing data on a daily basis as their dataset. In contrast, in this study, alongside 15-minute short periods, technical indicator data will be utilized for Bitcoin price prediction. Although previous studies have sparingly employed technical indicators, no prior research has undertaken any grouping based on the characteristics of these indicators in their utilization. Nevertheless, in this study, technical indicators will be grouped according to their attributes, and one indicator from each group will be selected for utilization in the prediction process.

In this study, three different datasets were utilized. One indicator from each of the indicator groups was selected, resulting in a dataset that encompasses four indicators and also includes Bitcoin's 15-minute closing values. All of the datasets cover the time period between February 12, 2022, at 03:00, and July 3, 2023, at 22:30. All the data used in

this study was obtained from the Matriks Database Platform. Matriks is a data provider affiliated with Matriks Bilgi Dağıtım A.Ş. Within the Matriks platform, these data are sourced from the Binance cryptocurrency exchange. The technical indicators used in this study are readily available for analysis within the Matriks Veri Terminali platform and are among the most commonly utilized indicators by professionals in the field.

Table 1: Dataset

Type	1st Group	2nd Group	3rd Group
	Bitcoin Closing Price	Bitcoin Closing Price	Bitcoin Closing Price
Momentum	RSI	Stokastik Slow	MOM
Volatility	Bolinger Bandları	ATR	Kleter
Trend	MOV(200)	MACD	ADX
Volume	OBV	MFI	CHF

Technical indicators are mathematical calculation methods and graphical tools used in financial markets. These indicators aim to provide information about market trends and price movements by measuring the direction, momentum, and volatility of prices. They can assist investors in gaining a better understanding of market movements and making more informed investment decisions, thereby reducing their risks. Technical indicators can be categorized into four different groups. The first group is Momentum-based indicators. Momentum-based technical indicators are tools that measure the existing momentum in the market and provide insights into the direction of price trends. They assist investors in gauging the strength of specific trends by quantifying strong movements in the market. Consequently, they are frequently employed indicators in technical analysis. The RSI (Relative Strength Index), which is a momentum-based indicator, takes values between 0 and 100. RSI is a tool that uses closing prices to identify overbought and oversold levels in the market. (Pring, 1997) The stochastic oscillator, represented by two distinct lines %K and %D, takes into account both the closing prices and the highest and lowest values within a specific period to identify overbought and oversold levels. (Perşembe, 2021) The momentum indicator used in the study calculates changes in prices over a specific period, comparing recent price changes with previous ones. This helps in predicting market direction changes. (Perşembe, 2021)

Volatility-based indicators are technical analysis tools used to measure price fluctuations in the market. These indicators show that when volatility increases, prices tend to either rise or fall, and when volatility decreases, prices are less variable. They assist investors in measuring price volatility and developing risk management strategies, making them a commonly used indicator in technical analysis.

The Bollinger Bands used in the study are an indicator that creates bands based on a certain standard deviation above and below moving averages. These bands are used to measure price volatility, with narrow bands indicating low volatility and expanded bands indicating high volatility. (Perşembe, 2021) Another indicator known as ATR (Average True Range) is used for measuring price volatility. This indicator calculates the difference between the high and low points of prices, aiding in the measurement of price volatility. (Öndaş, 2018) Keltner Channels are channels located above and below moving averages, and they are used to measure price volatility. When these channels narrow, it indicates a decrease in volatility, while when they widen, it signifies an increase in volatility. (Ceballos vd.,2017)

The third group of indicators, known as trend-following indicators, are tools used to monitor the trend of a specific asset price. These indicators are employed to determine the direction and strength of a trend and assist in predicting trend reversals in the market. They aid investors in identifying trends and predicting trend reversals in the market, making them a commonly used indicator in technical analysis. Moving averages represent the average of prices over a specific time period. This indicator is used to assist in determining the direction of a trend, and when prices rise above the moving average, it is interpreted as an uptrend, whereas when prices fall below it, it is considered a downtrend. (SARI, 2001). Another indicator is MACD (Moving Average Convergence Divergence). MACD is created by subtracting two moving averages from each other, is an indicator used to determine the direction of a trend. When the MACD line crosses the signal line, it is considered a potential signal for trend reversals. (Perşembe, 2021) Lastly, ADX (Average Directional Index) is an indicator used to measure the strength of a trend. This indicator provides information about whether a trend is likely to continue or reverse. (Perşembe, 2021)

As the fourth group, Volume and Money Flow indicators are technical analysis tools used to provide information about the health of a market. They assist investors in gaining a better understanding of price movements and are therefore frequently used indicators in technical analysis. On Balance Volume (OBV) measures the relationship between volume and price movements. OBV indicates the strength of buyers when prices rise and volume increases, whereas it signifies the strength of sellers when prices decline and volume rises. (Perşembe, 2021)." The Money Flow Index (MFI) measures the relationship between volume and price movements while also taking into account money inflow and outflow. MFI indicates the strength of buyers when there is an increase in volume and money flow alongside rising prices, whereas it signifies the strength of sellers when there is an increase in volume but a decrease in money flow alongside falling prices. (Perşembe, 2021). Third, The Chaikin Money Flow (CMF) measures the relationship between volume and price movements while also considering money flow. This indicator indicates the strength of buyers when there is an increase in volume and money flow alongside rising prices, whereas it signifies the strength of sellers when there is an increase in volume but a decrease in money flow alongside falling prices. (Thomsett, 2010)

4. Methodology

Artificial Neural Networks (ANNs), a machine learning technique inspired by the transitions in the human brain, consist of a series of interconnected neural cells (neurons). These neurons process inputs and, as a result, produce outputs (Elmas, 2011).

Recurrent Neural Networks (RNNs), on the other hand, offer a directed cycle where the neuron's output can be directly applied to itself at the next time step. This directed cycle enables RNNs to solve the problem of input dependencies both before and after the current input. To address the issues of long-term dependencies in neural networks and the vanishing/exploding gradient problems in traditional RNN models, Hochreiter and Schmidhuber introduced the Long Short-Term Memory (LSTM) architecture in 1997. LSTMs are designed to better store and access information, making them a fundamental model that can be used as a basis for other models (Jin, vd., 2020).

LSTM networks are a subset of RNNs. They enhance and extend temporary memory information by offering different gates that work somewhat like add or delete buttons to adjust the network's neuron state. These models are valuable in various language modeling tasks, effectively handling the task of sequential pattern recognition in text data as it flows through the model with the input words. The LSTM model is a powerful recurrent neural system specially designed to overcome the typical problems of exploding/vanishing gradients, which are associated with difficulties in training artificial neural networks due to long-term dependencies and the high data requirements, even when there are significant delays in learning.

This model consists of four gates with specific functions: the input gate, the cell state, the forget gate, and the output gate. These gates typically employ sigmoid or tanh activation functions (Selvin, vd., 2017).

Input Gate: The input gate takes the previous hidden state and the current input and processes them through a sigmoid function to determine what information should be updated in the cell state.

Cell State: The cell state, often referred to as the memory cell, stores and controls the flow of information over time. It can either store important information or forget irrelevant details based on inputs from other gates.

Output Gate: The output gate produces the final output of the LSTM cell, which can be considered the current hidden state of the cell. It takes into account the cell state and the input to generate the output.

Forget Gate: The forget gate decides which parts of the cell state should be erased or forgotten and which parts should be retained for future use. It does this by processing the previous hidden state and the current input through a sigmoid function.

These gates, by working together, enable an LSTM cell to effectively manage and update information over sequences, making it suitable for tasks involving long-term dependencies and sequential data processing.

Let i_t , f_t , o_t , c_t , and h_t represent the input gate, forget gate, output gate, cell state, and hidden state values at time t , respectively. The input vector at time t can be defined using the sigmoid activation function, as well as the parameter matrix W and vector b , as observed in Figure 2, employing Equations 3-7 (Andi, 2021).

$$\text{Equation (3): } i_t = \sigma(Wx_ix_t + Wh_ih_{t-1} + Wc_ic_{t-1} + b_i)$$

$$\text{Equation (4): } f_t = \sigma(Wx_fx_t + Wh_fh_{t-1} + Wc_fc_{t-1} + b_f)$$

$$\text{Equation (5): } c_t = f_t \odot c_{t-1} + i_t \odot \tanh(Wx_cx_t + Wh_ch_{t-1} + b_c)$$

$$\text{Equation (6): } o_t = \sigma(Wx_ox_t + Wh_oh_{t-1} + Wc_oc_t + b_o)$$

$$\text{Equation (7): } h_t = o_t \odot \tanh(c_t)$$

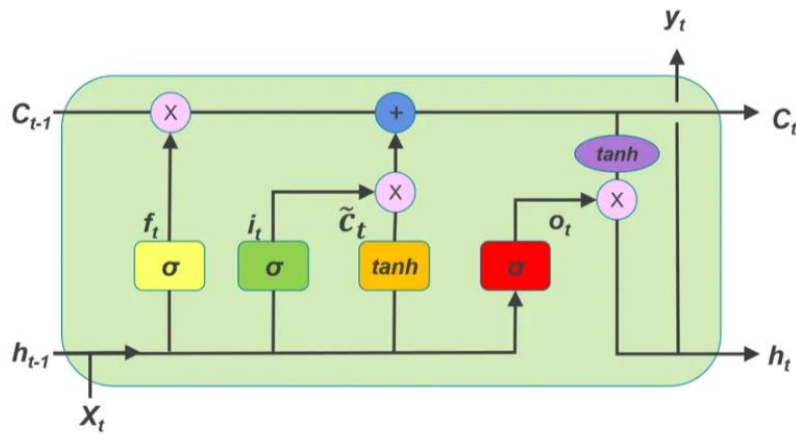

Figure 1: LSTM Model 1 (Source: Gürbüz, 2021)

In our study a multivariate time series model has been developed using LSTM neural network for our prediction. As shown in Figure 2, the developed model consists of three LSTM network layers with than activation and a 25% dropout for each layer to prevent overfitting. The model is implemented in the Tensorflow Keras environment. The number of cells in each LSTM layer was obtained using Keras hiperparameter optimization. The model uses Adam optimization with a learning rate of $\beta = 0.2$.

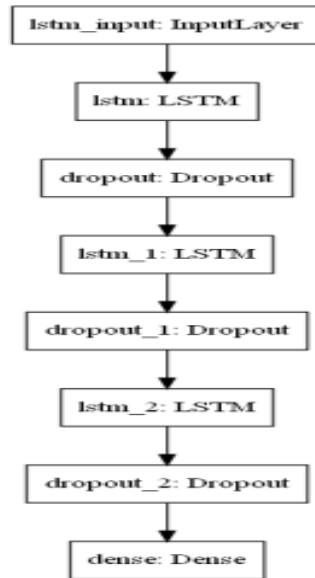

Figure 2: LSTM Model 2 (Source:Tanişman vd., 2021)

5. Results

In this section, the sum of the prediction results made with ANN models. The MSE value of the prediction model made with the first data set was obtained as 0.224. The indicators in the relevant data set are RSI, BOLLINGER, MOV200 and OBV, which are the most loved by analysts in the market. The error value of the prediction made with the data set most used by analysts was the lowest. The results show that the data obtained using the most used indicators are stored and brought to close values. As can be seen in the chart, long-term approaches are shown in similar oscillations and reactions are slow in sudden movements.

	Close
2023-03-07 22:30:00	23123.162109
2023-03-07 22:45:00	23246.201172
2023-03-07 23:00:00	23126.457031
2023-03-07 23:15:00	23125.281250
2023-03-07 23:30:00	23105.878906
2023-03-07 23:45:00	23087.478516
2023-03-08 00:00:00	23202.523438
2023-03-08 00:15:00	23071.683594
2023-03-08 00:30:00	22950.576172
2023-03-08 00:45:00	23050.443359

Figure 3: Predictions Model 1

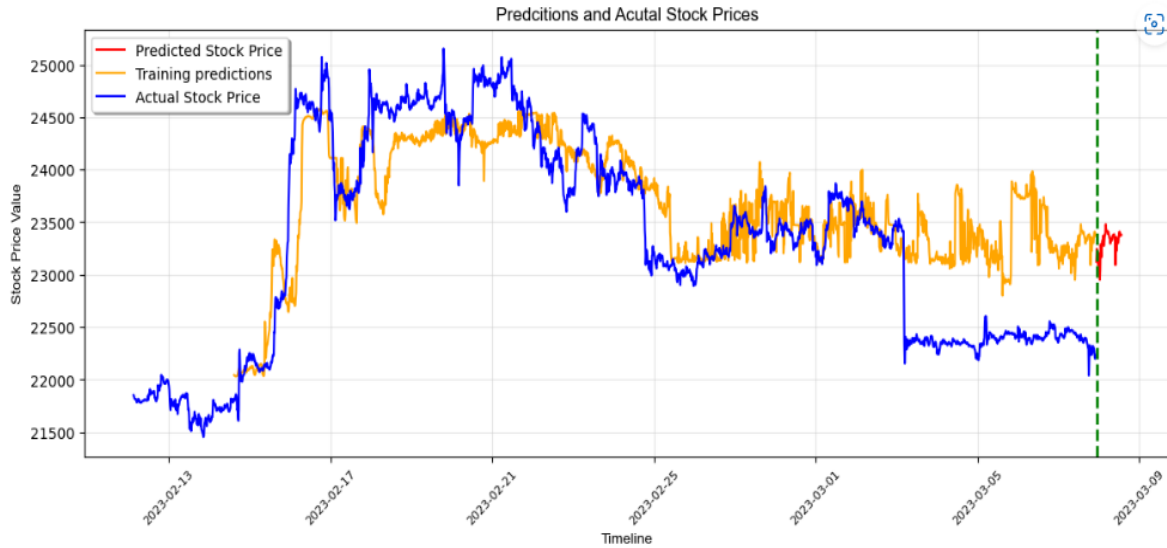

Figure 4: Predictions Model 1

The data set of the 2nd forecast model includes STOCK, ATR, MACD and MFI. When the prediction results are examined, the MSE value is 0.5396. The selected indicators are used by analysts who study the market in detail. Analysts in the market use these indicators to react to sharp movements. As can be seen from the graph, although the model gives sudden reactions to sharp movements while remaining stable, and although sudden reactions in horizontal markets can be measured, it cannot capture the movements in horizontal markets to a sufficient extent. No matter how high the error value, it emerged as the model that achieved the second best result.

	Close
2023-03-07 22:30:00	23129.052734
2023-03-07 22:45:00	23130.033203
2023-03-07 23:00:00	23130.427734
2023-03-07 23:15:00	23129.658203
2023-03-07 23:30:00	23130.660156
2023-03-07 23:45:00	23130.755859
2023-03-08 00:00:00	23129.464844
2023-03-08 00:15:00	23130.291016
2023-03-08 00:30:00	23130.806641
2023-03-08 00:45:00	23132.416016

Figure 5: Predictions Model 2

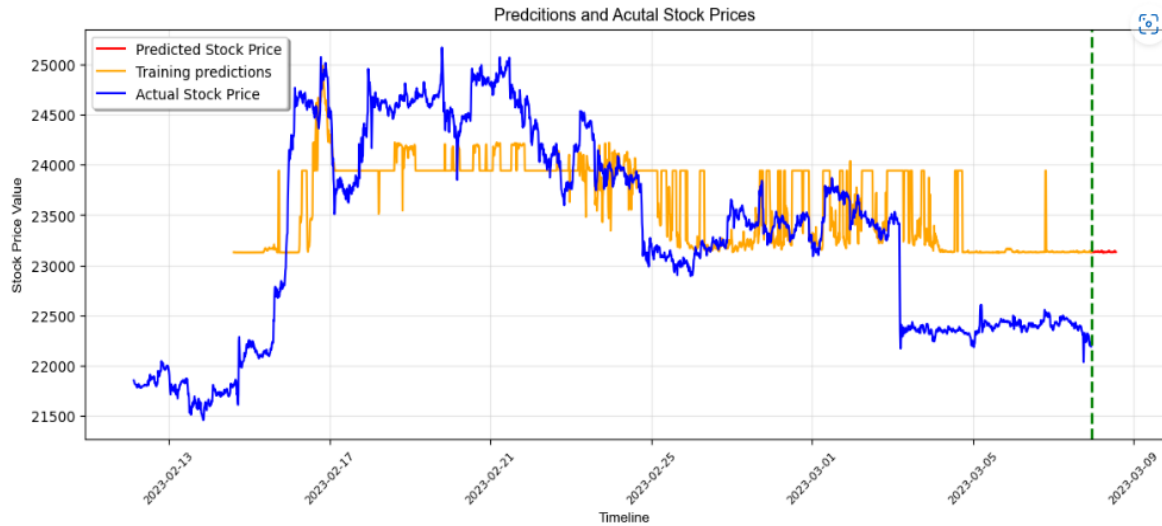

Figure 6: Predictions Model 2

The MSE value of the final model consisting of MOM, KLETER, ADX and CHF is 0.6502. The indicators in the relevant data set are among the least used indicators on the market. The values they take are generally close to constant in short periods. The most unsuccessful results were obtained with the prediction we made with the data set consisting of rarely used indicators.

	Close
2023-03-07 22:30:00	23287.003906
2023-03-07 22:45:00	23287.003906
2023-03-07 23:00:00	23287.003906
2023-03-07 23:15:00	23287.003906
2023-03-07 23:30:00	23287.003906
2023-03-07 23:45:00	23287.003906
2023-03-08 00:00:00	23287.003906
2023-03-08 00:15:00	23287.003906
2023-03-08 00:30:00	23287.003906
2023-03-08 00:45:00	23287.003906

Figure 7: Predictions Model 3

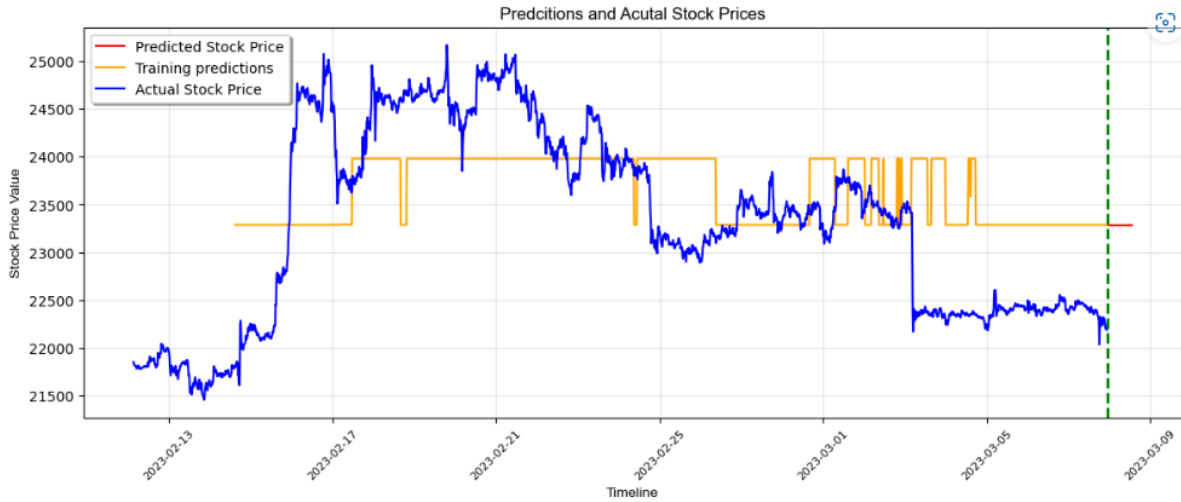

Figure 8: Predictions Model 3

6. Conclusions

This study highlights that forecasting techniques and models are an important decision-making tool for individuals and organizations. In particular, these techniques and models have gained even more importance under the influence of new financial products such as Bitcoin, which have attracted the attention of investors along with the developments and innovations in the financial world.

The study uses the LSTM model to predict future price movements of Bitcoin. Three separate data sets were used for these estimates, each containing one indicator from different indicator types. Examining these data sets aims to provide a basis for predicting future data on Bitcoin's performance. Additionally, the study also considers three different governance scenarios for Bitcoin, thus providing a risk mitigation strategy for investors.

The results show that the first data set provides more accurate predictions than the others. However, during periods of high Bitcoin volatility, the reliability of predictions has decreased. Therefore, the study suggests that methods such as using shorter-term data sets or different indicators can contribute to the literature.

As a result, this study aims to provide guidance to Bitcoin investors and offer risk mitigation strategies. It also points out that using a larger data set or different indicators in financial forecasts can provide better results.

References

- Alpago, H. (2018). Bitcoin'den Selfcoin'e kripto para. *Uluslararası Bilimsel Araştırmalar Dergisi*, 3(2), 411- 428.
- Andi, H. K. (2021). An accurate bitcoin price prediction using logistic regression with LSTM machine learning model. *Journal of Soft Computing Paradigm*, 3(3), 205-217.
- Atlan, F., Pençe, I., Çeşmeli, M. S., Kalkan, A. (2018). Bitcoin'in Türkiye piyasasındaki değerinin yapay zeka teknikleri ile tahmini. In *5th International Management Information Systems Conference*. 59–62.
- Buchholz, M., J. Delaney, J. Warren, and J. Parker. (2012). Bits and bets, information, price volatility, and demand for bitcoin. *Economics* 312.
- Ceballos, L. E. F., Gómez, L. M. J., Gonzales, C. D. C. P., and Torres, G. A. A. (2017). Revisión de investigaciones empíricas sobre la aplicación del análisis técnico en los mercados financieros.(Review of empirical research on the application of technical analysis in financial markets). *Revista En-contexto*, (7), 113-125.
- Chen, J. (2023). Analysis of bitcoin price prediction using machine learning. *Journal of Risk and Financial Management*, 16(1), 51.

- Chen, Z., Li, C., and Sun, W. (2020). Bitcoin price prediction using machine learning: An approach to sample dimension engineering. *Journal of Computational and Applied Mathematics*, 365, 112395.
- De Bondt, W. F., and Thaler, R. (1985). Does the stock market overreact?. *The Journal of finance*, 40(3), 793-805.
- Elmas, C. (2011). *Yapay zeka uygulamaları*. Ankara: Seçkin Yayıncılık,
- Gencer, A. H. (2017). Forecasting The Bitcoin Price Via Artificial Neural Networks. *International Conference On Eurasian Economies*.
- Graves, A. (2013). Generating sequences with recurrent neural networks. *arXiv preprint*
- Gürbüz, Batıncan. (2021). "Uzun Kısa Dönemli Bellek (Long Short-Term Memory - LSTM)." *Medium*. URL: <https://medium.com/@batincangurbuz/uzun-k%C4%B1sa-d%C3%B6nemli-bellek-long-short-term-memory-lstm-c526980c28b1>
- Hamayel, M. J., and Owda, A. Y. (2021). A novel cryptocurrency price prediction model using GRU, LSTM and bi-LSTM machine learning algorithms. *AI*, 2(4), 477-496.
- Hochreiter, S. (1997). Longshort-termmemory. *NeuralComput*9 (8): 1735–1780.
- Huang, X., Zhang, W., Tang, X., Zhang, M., Surbiryala, J., Iosifidis, V., and Zhang, J. (2021). LSTM based sentiment analysis for cryptocurrency prediction. In *Database Systems for Advanced Applications: 26th International Conference, DASFAA 2021, Taipei, Taiwan, April 11–14, 2021, Proceedings, Part III 26* (pp. 617-621).
- Jin, Z., Yang, Y., and Liu, Y. (2020). Stock closing price prediction based on sentiment analysis and LSTM. *Neural Computing and Applications*, 32, 9713-9729.
- Johnston, M. (2023). *Stock trading bot: Coding your own trading algo*. Access date: 10.05.2023
- Karevan, Z., and Suykens, J.A. (2020). Zaman serisi tahmini için transdüktif LSTM: Hava tahmini için bir uygulama. *Sinir Ağları* , 125 , 1-9.
- Kwon, D. H., Kim, J. B., Heo, J. S., Kim, C. M., and Han, Y. H. (2019). Time series classification of cryptocurrency price trend based on a recurrent LSTM neural network. *Journal of Information Processing Systems*, 15(3), 694-706.
- Latif, N., Selvam, J.D., Kapse, M., Sharma, V., and Mahajan, V. (2023). Bitcoin fiyatlarının kısa vadeli tahmini için LSTM ve ARIMA'nın karşılaştırmalı performansı. *Australasian Accounting, Business and Finance Journal* , 17 (1), 256-276.
- Livieris, I. E., Kiriakidou, N., Stavroyiannis, S., and Pintelas, P. (2021). An advanced CNN-LSTM model for cryptocurrency forecasting. *Electronics*, 10(3), 287.
- Luo, C., Pan, L., Chen, B., and Xu, H. (2022). Bitcoin price forecasting: an integrated approach using hybrid LSTM-ELM models. *Mathematical Problems in Engineering*.
- Öndaş, M. (2018). ATR indikatörü nedir ve nasıl kullanılır? Access date: 20.07.2018,
- Perşembe, A. (2010). *Teknik analiz mi dedin? hadi canım sen de!* Üçüncü Kitap. İstanbul: Scala Yayıncılık.
- Pring, M. J. (1993). *Martin Pring on market momentum*. Texas: McGraw-Hill
- Şahin, E. E. (2018). Kripto para Bitcoin: ARIMA ve yapay sinir ağları ile fiyat tahmini. *Fiscoeconomia*, 2(2), 74-92.
- Sarı, Y. (2001). *Borsada Göstergelerle Teknik Analiz*. 4. Basım. İstanbul: Alfa Yayınevi.
- Sel, A., Zengin, N., and Yıldız, Z. (2020). Alternatif yatırım araçları ile Bitcoin fiyatları arasındaki ilişkinin yapay sinir ağları ile tahmini. *Sivas Cumhuriyet Üniversitesi İktisadi ve İdari Bilimler Dergisi*, 21(2), 157-169.
- Selvin, S., Vinayakumar, R., Gopalakrishnan, EA, Menon, VK ve Soman, KP (2017). LSTM, RNN ve CNN kayan pencere modeli kullanılarak hisse senedi fiyat tahmini. *Bilgi işlem, iletişim ve bilişimdeki ilerlemeler üzerine uluslararası konferans* ,1643-1647.
- Struga, K. and Qirici, O. (2018). Sinir Ağları ile Bitcoin Fiyat Tahmini. *RTA -CSIT*'te, 41-49.
- Tanişman, S., Karcıoğlu, A. A., Uğur, A., & Bulut, H. (2021). "LSTM Sinir Ağı ve ARIMA Zaman Serisi Modelleri Kullanılarak Bitcoin Fiyatının Tahminlenmesi ve Yöntemlerin Karşılaştırılması." *Avrupa Bilim ve Teknoloji Dergisi*, Özel Sayı 32, 514-520. [To Access the Image] <https://dergipark.org.tr/tr/download/article-file/2145414>
- Thomsett, M. C. (2010) *CMF-Chaikin money flow: Changes anticipating price reversal*. New Jersey :FT Press
- Wardak, AB ve Rasheed, J. (2022). Uzun kısa süreli bellek tekrarlayan sinir ağı kullanarak bitcoin cryptocurrency fiyat tahmini. *Avrupa Bilim ve Teknoloji Dergisi* , (38), 47-53.
- Yavuz, U., Üstün, Ö., Taş K., and Çağlar, B. (2020). Yapay sinir ağları ile blockchain araştırmalarına dayalı bitcoin fiyat tahmini. *Bilgi sistemleri ve yönetim araştırmaları dergisi* , 2 (1), 1-9.

Ye, Z., Wu, Y., Chen, H., Pan, Y., and Jiang, Q. (2022). A stacking ensemble deep learning model for bitcoin price prediction using Twitter comments on bitcoin. *Mathematics*, 10(8), 1307.